



TECHMATIK[®]
A COLUMBIA MACHINE, INC. COMPANY

USER MANUAL FOR MOLDS

www.techmatik.com



MOLDS FOR PRODUCTION OF CONCRETE PRODUCTS (STANDARD MOLD)

Product name	Standard mold
Identification	Nameplate in the upper and lower part of the mold
Mold No.	See nameplate
Production date	See nameplate
Weight	See nameplate
Manufacturer and address	Techmatik S.A. ul. Żółkiewskiego 131/133 26-610 Radom phone +48 48 369 08 00 fax +48 48 369 08 01

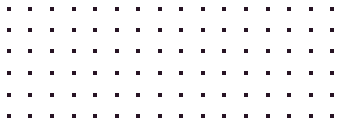

CONTENTS	PAGE
1. Conditions of safe use	4
1.1. Intended use	4
1.2. Responsibilities of the employer	4
1.3. Training of the operating personnel	4
1.4. Responsibilities of an employee	4
2. Safety rules	5
2.1. Explanation of symbols	5
2.2. Training of the operating personnel	6
2.3. Personal protection equipment	6
2.4. Safe use	7
2.5. Adverse effects	8
3. Information for the user	9
4. Description of the product	10
4.1. Main elements of the mold	10
4.2. Production process	12
4.3. Technical parameters	14
4.4. Tightening of bolts – Technical parameters	14
5. Transport and lifting	16
6. Use	18
6.1. Assembly of the mold in the concrete block machine	19
6.2. Quality assurance, prevention of failures	21
6.3. Cleaning during the production process	23
6.4. Disassembly	23
6.5. Disassembly after damage or failure	24
7. Maintenance and shipment for repair	25
7.1. Cleaning after disassembly	26
7.2. Maintenance and storage	28
7.3. Control and repairs	28
7.4. Shipment for repair	28
8. Disassembly and waste disposal	31
9. Contact details	32

1. CONDITIONS OF SAFE USE.

The mold for the production of vibropressed concrete products was made in accordance with the state-of-the-art technology and applicable safety rules. While using the mold, there may occur certain hazards which could lead to health injuries or risk to life of the users and third parties, and also to damage of the property, in particular, in the event of improper use or use that is not compliant with the intended purpose. These operating instructions contain a description and guidelines which are important for the safe use of the molds. Additionally, it is necessary to observe the legal regulations as well as occupational health and safety regulations applicable at the location where the mold is used.

1.1. Intended use

The mold may only be used for the production of vibro-pressed concrete products. The intended use must also be understood as the observance of all remarks and guidelines included in these instructions

1.2. Responsibilities of the employer.

The employer is obliged to:

- store these instructions nearby the site where the mold is installed and used,
- only allow the operation of the mold by persons who:
- read and understood these operating instructions,
- underwent basic training in occupational health and safety regulations at the work post,
- were trained in the safe operation of the molds,

1.3. Training of the operating personnel

Only the appropriately trained personnel may be allowed to operate the machines equipped with molds and to perform all activities related to the service, installation, maintenance and disassembly of the mold.

1.4. Responsibilities of the user

Each user is obliged to become familiar with these operating instructions and observe all the included recommendations, in particular those regarding safety.

2. SAFETY RULES.

Molds must be used only as intended - for the production of vibropressed concrete products. The use of molds in a manner which is not compliant with their intended purpose may also cause risks to the user's health and property and damage to the mold. The improper operation of the mold or failure to observe the safety rules and warnings may also cause risk to third parties. The consequence of use which is improper or not compliant with the intended purpose may be death, severe injury or major material damage.

2.1. Explanation of symbols

All the guidelines regarding safety and warnings are marked clearly in these instructions. The following symbols are assigned to the warnings.



The necessity to become familiar with the operating instructions



Note! This symbol warns against the hazards which may lead to bodily injury or even death, or which may cause significant material damage.



Failure to observe these recommendations may cause material damage.



Use safety glasses.



Use protective footwear.



Use protective masks.



Use protective gloves.



Use protective helmets.

2.2. Training of the operating personnel.



HAZARDS FOLLOWING FROM THE INSUFFICIENT TRAINING OF THE PERSONNEL.

Before proceeding with the use of the mold, it is absolutely necessary to train the operating personnel. It is possible to start using the mold:

- after reading these operating instructions,
- after an additional training regarding the safe use of the mold,
- when the occupational health and safety regulations are observed
- remembering that these operating instructions must always be available.



IT IS PROHIBITED TO USE THE MOLDS AND MACHINERY IN WHICH THEY WERE INSTALLED:

- under the influence of alcohol,
- under the influence of narcotics and other drugs,
- under the influence of medicines which affect the psychomotor capability.

2.3. Personal protection equipment.



HAZARD CAUSED BY FALLING HEAVY ELEMENTS

- While working with the mold, always wear protective footwear.
- Furthermore, use personal protection equipment which is provided for the given activity according to the plant regulations.
- Observe the internal occupational health and safety instructions



HAZARD CAUSED BY EJECTED ELEMENTS AND COMPRESSED AIR

- Always wear safety glasses and protective gloves.
- Concrete elements or dust particles may be ejected from the mold under the influence of compressed air.



HAZARD CAUSED BY EJECTED ELEMENTS AND WATER JET

- Always wear safety glasses and protective gloves.
- Also, observe the safety instructions included in the manual of the used cleaning device.
- Concrete fragments may be ejected from the mold under the influence of water pressure in the cleaning device.



HAZARDS CAUSED BY A PRESERVATIVE

- Always wear safety glasses and protective gloves.
- Observe the guidelines given in the material safety data sheet attached to the used preservative.
- Do not breathe in the preservatives
- The shuttering oils may cause eye and skin irritation.



HAZARDS RELATED TO CONTACT WITH SHARP EDGES

- Always wear protective gloves-the protective gloves allow for the avoidance of injuries caused by sharp edges during the cleaning of the mold.

2.4. Safe use.



HAZARD CAUSED BY IMPROPER USE

- The molds must only be used in accordance with their intended purpose.
- Otherwise, the operating personnel is exposed to a hazard which may result in severe bodily injuries or significant material damage.



HAZARD CAUSED BY PROHIBITED MODIFICATIONS

- Do not introduce any modifications or alterations in the mold or its parts without prior consent from the manufacturer.
- Any unauthorised alteration in the construction may lead to damage to the mold, which may result in severe bodily injuries or cause material damage.



HAZARD CAUSED BY FALLING HEAVY ELEMENTS

- Do not stand or walk under suspended loads.
- It is allowed to transport the mold only by persons with appropriate skills and licences for the operation of lifts.
- Make sure that the load-bearing capacity of the used lift is sufficient. The weight of the mold is given on the nameplate



HAZARD CAUSED BY HEAVY ELEMENTS FALLING DURING TRANSPORT

- If the mold is transported using a forklift truck, it must be placed on the transport pallet.
- The mold must be protected against movement and falling.
- To lift both the lower and upper part of the mold, only the use of handles intended for this purpose is allowed.
- Use only the allowed auxiliary measures with sufficient load-bearing capacity.



HAZARD CAUSED BY THE MOVEMENT OF HEAVY ELEMENTS

- In order to transport the mold with a truck, it must be protected against movement.
- Under the pallet, place a spacer, which prevents the uncontrolled movement when driving.

2.5. Adverse effects.



The production on the machine (concrete block machine) is not allowed, until the mold for production of concrete products is installed correctly in accordance with the manufacturer's operating instructions, using all the regulations applicable at the workpost. The frequently encountered irregularities include:

- The setting of incorrect machine parameters.
- The transport of the mold with an improper means of transport and in an improper manner.
- The use of the mold by the insufficiently trained personnel.

3. INFORMATION FOR THE USER.



These operating instructions contain important guidelines, which allow for the safe operation of the mold and the maintenance of its good working order. The mold constitutes an element of the auxiliary equipment of the machine for the production of concrete elements. For the safe disassembly and assembly of the mold, as well as its safe operation, it is necessary to observe the operating instructions of the machine (concrete block machine) for the production of concrete elements.

Additionally, the occupational health and safety regulations for the given workpost, which are applicable at the production site, must be observed.



The maintenance and repair work may be conducted only using a mold which is disassembled from the machine and by the personnel which has appropriate knowledge and skills.

4. DESCRIPTION OF THE PRODUCT.

The standard mold is an element of the machine (concrete block machine) for the production of vibropressed concrete products, designed and executed only for industrial production on a specific machine type.

4.1. Main components.

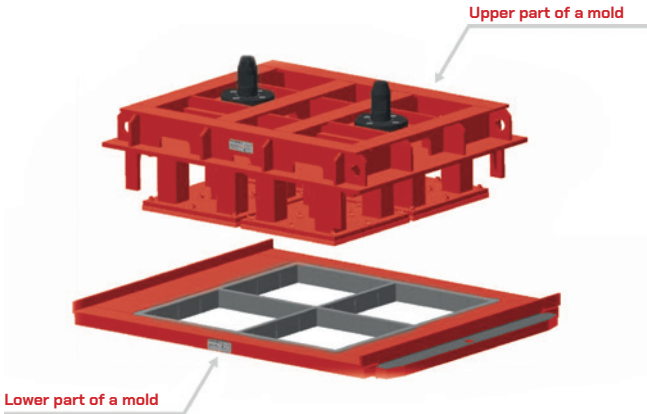

Fig. 1 - Main Components of the mold

Upper part of a mold consists of two basic components:

- mold compression head
- feet (compression head plates)

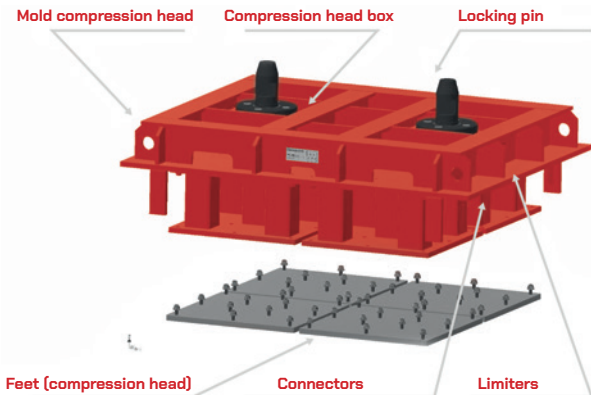

Fig. 2 - Main components of the upper part of the mold

The compression head mold consists of the compression head box, connectors and components which connect the compression head with the crossbar, such as, among others, pins.

Lower part of the mold - die.

The die is fixed in the clamps of the machine (concrete block machine) by means of pressure beams.

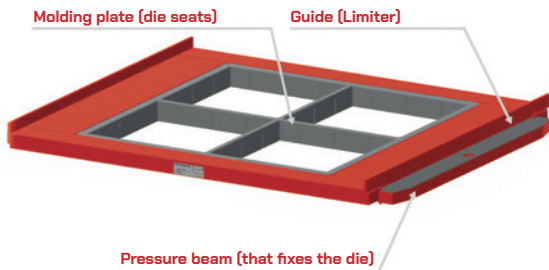

Fig. 3 - Lower part of the mold

The non-standard element of the mold is the backing sheet which serves the purpose of forming of the product's underside. Depending on the machine type, the sheet is made on one piece of sheet metal or, in particular cases, only by means of the so called forming rails.

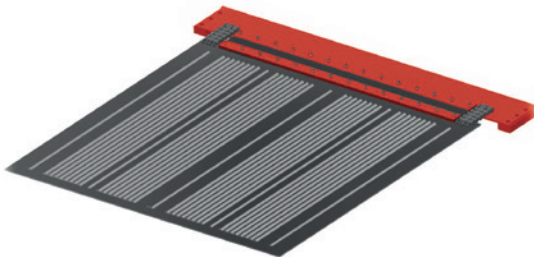

Fig. 4 - Backing sheet for forming of the stone's underside.

4.2. Production process



THE PROCESS OF PRODUCTION OF CONCRETE ELEMENTS, USING THE STANDARD STEEL MOLD

The cavities of the forming plate in the die are filled with moist concrete.

Then, the concrete is distributed uniformly in the die seats under the influence of vibrations.

The compression head with the feet is lowered to the level of the die and the concrete is subjected to vibro-pressing.

Another stage is the lifting of the die up and the pushing of the molded products out of the seats.

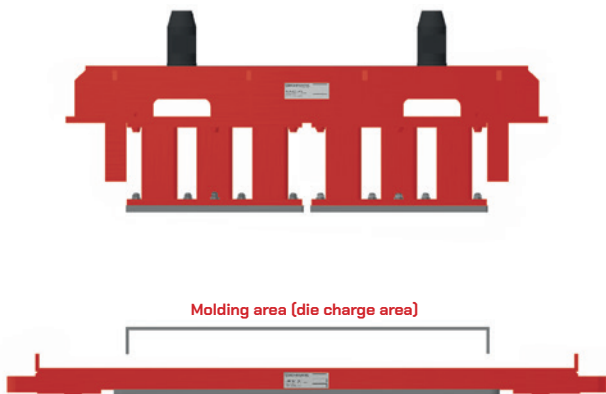

Fig. 5 - View of the mold during the charge.

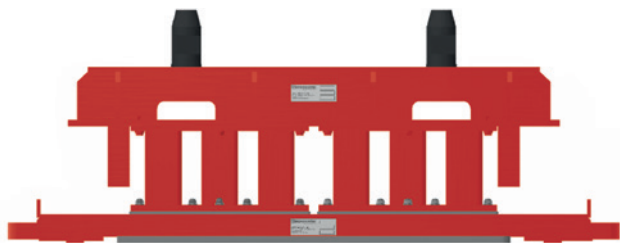

Fig. 6 - View of the mold during the concrete vibropressing.

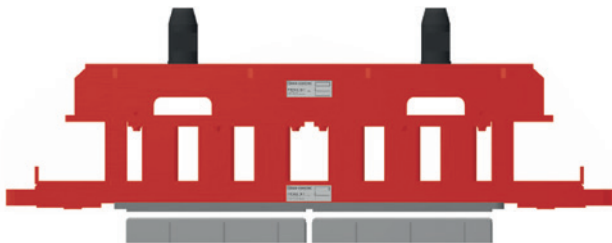

Fig. 7 - View of the lifted mold after the finished molding process with a visible produced material.

4.3. Technical parameters

The mold is an element of the auxiliary equipment of a specific machine for production of vibropressed concrete products (e.g. paving sett) and was, therefore, executed in accordance with the requirements of the specific machine. Therefore, the technical parameters of the mold may vary. The weight of a specific mold is specified in the nameplates on the dies and the compression head.

4.4. Tightening of bolts – Technical parameters



If the operating instructions of the machine do not specify otherwise, the torque values given in the tables below are valid.

Thread/bolt size (in metric)	Torque in Nm for bolts with the strength class indicator for total $\mu = 0.14$	
	8.8	10.9
M12	78	117
M14	126	184
M16	193	279
M18	270	387
M20	387	558
M24	666	954
M27	990	1395
M30	1350	1890

Thread/bolt size (in inches)	Torque in lb-ft for bolts with the strength class indicator for total $\mu = 0.14$	
	Degree 5	Degree 8
UNC 1/4" -20	7	11
UNC 5/16" -18	18	26
UNC 3/8" -16	37	52
UNC 1/2" -13	64	90
UNC 5/8" -11	156	220
UNC 3/4" 10	304	427
UNC 7/8" -9	412	578
UNC 1" -8	524	738
UNC 1 1/4"	1049	1485
UNC 1 1/2"	1848	2601

5. TRANSPORT AND LIFTING.



HAZARD CAUSED BY FALLING HEAVY ELEMENTS

- While transporting the mold, always wear protective footwear.
- Furthermore, use personal protection equipment which is provided for the given activity according to the plant regulations.
- Observe the internal occupational health and safety instructions



HAZARD CAUSED BY FALLING HEAVY ELEMENTS

- Do not stand or walk under suspended loads.
- It is allowed to transport the mold only by persons with appropriate skills and licences for the operation of lifts.
- Make sure that the load-bearing capacity of the used lift is sufficient.
- The weight of the mold is given on the nameplate



HAZARD CAUSED BY FALLING HEAVY ELEMENTS

- In order to transport the mold with a forklift truck, It is necessary to place it on the transport pallet.
- The mold must be protected against movement and falling.



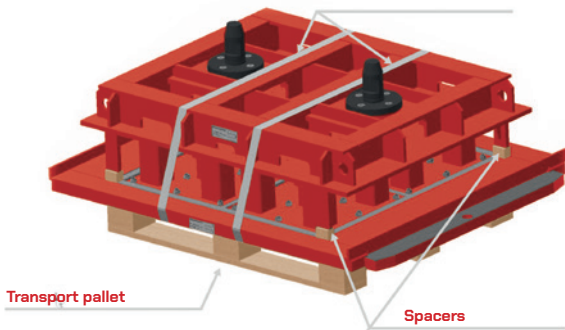

Fig. 8 - The way to secure the mold on the transport pallet.



HAZARD CAUSED BY FALLING HEAVY ELEMENTS

- Both the die and the compression heads may only be lifted on elements provided for this purpose.
- Use only the allowed means of transport with sufficient load-bearing capacity.
- Chains and belts for the lifting and transport must be placed outside the mold cavities. This allows the damage to the edges of the mold cavities to be eliminated.
- Make sure that the lifting belts are not guided along sharp edges.
- The belts must be protected against wear using the protective corners of the edges.

6. USE.



HAZARD CAUSED BY THE INSUFFICIENTLY TRAINED PERSONNEL

It is possible to start using the mold:

- after reading these operating instructions,
- after an additional training regarding safe use of the mold,
- when the occupational health and safety regulations are observed,
- remembering that these operating instructions must always be available to the user



HAZARD CAUSED BY FALLING HEAVY ELEMENTS

- During the control of the mold, always wear protective footwear.
- Use personal protection equipment which is provided for the given activity according to the plant regulations.
- Observe the in-house manuals and occupational health and safety regulations.



HAZARDS CAUSED BY SHARP EDGES

- Always wear protective gloves - the protective gloves allow for the avoidance of injuries by sharp edges during the cleaning of the mold.



HAZARD RESULTING FROM UNAUTHORISED MODIFICATIONS IN THE MOLD

- It is prohibited to introduce any modifications or alterations in the mold or its parts without prior consent from the manufacturer.
- It is prohibited to introduce any alterations or modifications in the mold or its parts without obtaining the prior consent from the manufacturer.



EACH TIME BEFORE USING THE MOLD:

- control the mold in terms of possible damage and check its completeness,
- check the joints with regards to cracks and ruptures,
- mark the damaged sites and notify the rescue services

6.1. Assembly of the mold in the concrete block machine

The mold constitutes an element of the equipment of the machine for the production of concrete products (concrete block machine).

Before the commencement of any assembly work, protect the work area against the access of unauthorised persons.

During all the work, observe all recommendations included in the operating instructions of the machine.

Service and repair activities may be conducted only by the personnel trained in the scope of the performed work.



SEQUENCE OF ACTIVITIES PERFORMED DURING THE ASSEMBLY OF THE MOLD

- The die and the compression head (except the machine) must be laid with the V-mark and the plate on one side.
- Remove the protective tapes. Remove the spacer only after the mold is mounted on the machine.
- Assemble the mold in the machine in accordance with the guidelines of the manufacturer.
- During the assembly of the mold use only the tools recommended by the manufacturer.
- Align the mold and the compression head in relation to each other, check the centring and remove the spacers.
- During the centring process, neither apply vibration at full load nor idle vibration. This allows for the avoidance of cracks or damage to the mold.

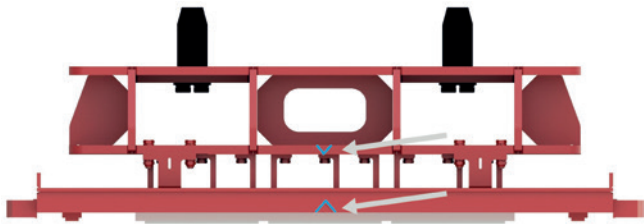

Fig. 9 - "V" incisions on the compression head and the die.

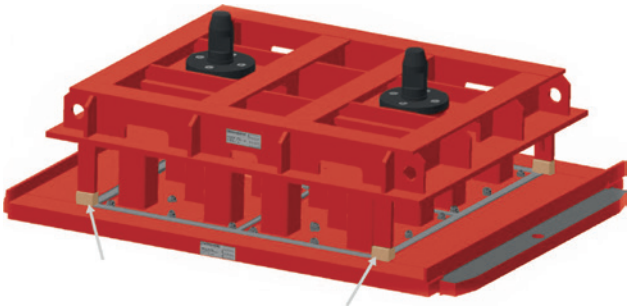

Fig. 10 - Mold prepared for the assembly on the machine with spacers provided between the die and the compression head limiter.

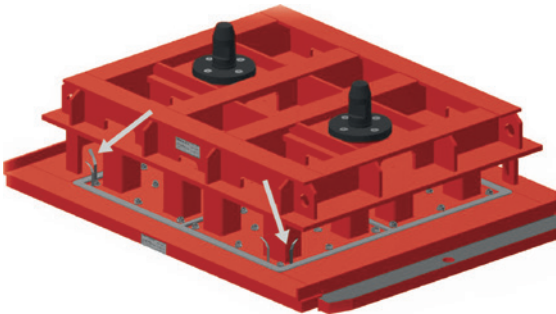

Fig. 11 - Method of checking of the mold centring, using feeler gauges.

- Check the centring by means of feeler gauges, placing them into corner sockets. After the check, remove them from the mold.
- Check if everything is properly installed and tightened.
- Before the production is started, check whether there are any tools or foreign elements on the mold or inside it - remove them, if necessary.

This allows for the elimination of possible damage to the mold by foreign material during its operation

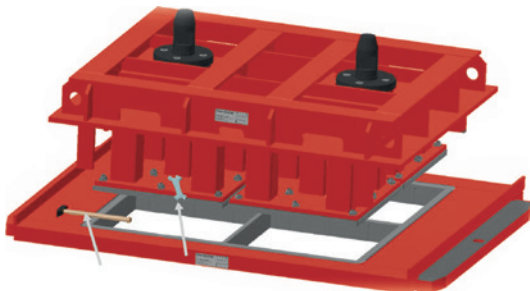

Fig. 12 - Example of the leaving of foreign material on the mold (e.g. a hammer, a key)

6.2. Quality assurance, prevention of failures.



CLEAN THE MOLD ONLY WITH WATER OR COMPRESSED AIR.

- In order to clean the mold cavities do not use tools with sharp edges such as a chisel, a screwdriver etc. Concrete deposits/buildups must be removed by means of a wire brush.
- Do not use a hammer or any impact tools, which may cause incisions, notches and cracks in the walls of the mold.
- The type of the used concrete mix affects the life of the mold.

Depending on the size of the grains and their shape, the weaker or more intense abrasion of the die cavities and feet takes place.

Control the quality of the produced concrete products.

If any quality defects are found:

- Check whether there are any residues of concrete on the mold cavities or compression head plates. If necessary, remove them using a wire brush.
- Check whether the die and the compression head are placed correctly and centrally.
- Check whether the compression head or the dies are not damaged. In particular, check the compression head plates and edges of the compression head plates.
- Check the mold cavities in terms of wear. In the event of significant wear, notify the relevant repair services.
- Check the adhesion of the die to the production board. If required, adjust the fixture.

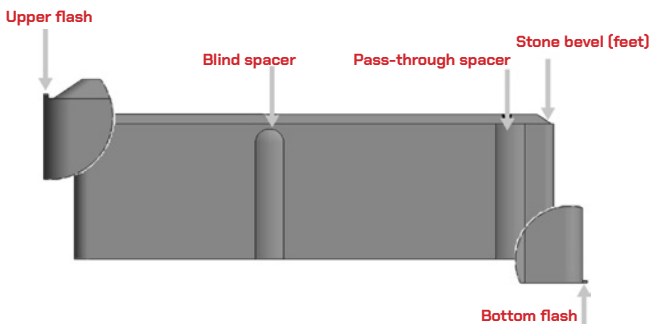

Fig. 13 - The most frequent cases of occurrence of defective products.

The figure above presents the damage to the product caused by:

- Bottom flash – lack of adhesion of the die to the production board – as a result of this, the so called „elephant’s foot” is produced.
- Upper flash – a shifted foot, non-centric operation of the compression head in relation to the die – causes fast wear of the feet and upper parts of the cavities.

In order to avoid production defects in concrete products, we also recommend regular controls of the vibration table with regards to its evenness and correct setting of the distance of counterblow bars.

The distance of the counterblow bars has a decisive impact on the value of the dynamic force.

Different spacings between counterblow bars which occur on the vibration table, cause diversified accelerations which affect the working tabletop and the die. These diversified accelerations may cause different amplitudes, and this, in turn, may cause the die to be lifted to a different height. As a consequence of this, concrete may flow out between the lower part of the die and the production board. Such a situation leads to dusting and damage to the lower edge of the mold, the so called “elephant’s foot” is produced.

6.3. Cleaning during the production process.



THE MOLD CONSTITUTES AN ELEMENT OF THE AUXILIARY EQUIPMENT OF THE MACHINE FOR THE PRODUCTION OF CONCRETE PRODUCTS.

- Protect the work area against the access of unauthorised persons.
- During all the work, observe all recommendations included in the operating instructions of the machine.



HAZARDS CAUSED BY EJECTED ELEMENTS AND COMPRESSED AIR

- Always wear safety glasses and protective gloves.
The use of compressed air may cause the ejection of concrete fragments or dust particles from the mold.

- Concrete deposits/buildups must be removed several times during a given day. Owing to this, quick wear of the mold will be avoided.
- If necessary, blow the mold through with compressed air during the production process using a “lance” (extension).

This guarantees permanent quality of the produced concrete products. The die must be cleaned from the top and from the bottom.

- Clean the compression head plates (feet) both from the bottom and along their circumference.
- If needed, the compression head and the die must be lubricated with cleaning oil or shuttering oil.

The die must be lubricated from the bottom.

- If the production on the mold takes place using the backing sheet, also lubricate the sheet.

6.4. Disassembly.



THE MOLD CONSTITUTES AN ELEMENT OF THE AUXILIARY EQUIPMENT OF THE MACHINE FOR THE PRODUCTION OF CONCRETE PRODUCTS.

If the disassembly of the mold is necessary:

- protect the work area,
- during the performance of all the activities, observe all recommendations included in the operating instructions of the machine.
- remember to put the mold away on the pallet after its disassembly.
- Protect the edges of the compression head plates (feet) by the insertion of spacers between the die and the compression head.

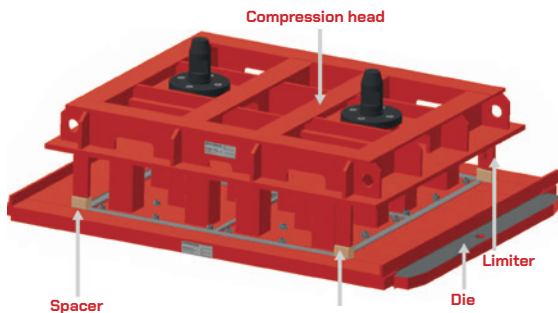

Fig. 14 - Mold with spacers.

When the mold is disassembled, place a spacer with an appropriate thickness between the limiter of the compression head and the die.

The spacer must guarantee that the edges of the compression head plates (feet) will be elevated by at least 10 mm above the bottom of the die.

- Remove the spacers only for production (after the mold is assembled on the machine).

This way, the edges of the compression head plates (feet) are protected against the possible damage during transport and storage.

6.5. Disassembly after damage or failure

The mold constitutes an element of the auxiliary equipment of the machine for the production of concrete products.

- Protect the work area.
- During the performance of all the activities, observe all the rules included in the operating instructions of the machine manufacturer.

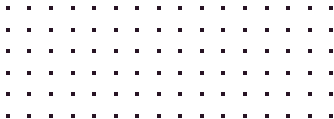



HAZARD CAUSED BY FALLING HEAVY ELEMENTS

- During the control of the condition of the mold, always wear protective footwear.
- Use the personal protection equipment recommended for a given activity in accordance with the plant regulations.
- Observe the plant occupational health and safety manuals.
- Do not stand or walk under suspended load.
- The transport of the mold is permissible only by the qualified personnel with licences to operate lifts.
- Determine the location where an element was torn off/cracked and the extent of the damage.
- Protect the torn elements against falling.
- Join the torn elements by means of ropes or chains.
- Lift the torn elements from the machine by means of an appropriate lifting device.
- If necessary, inform the relevant repair services.
- Secure the mold against use during its repair.

The repair of the mold may be carried out only by the qualified personnel!

7. MAINTENANCE AND SHIPMENT FOR REPAIR.



HAZARD CAUSED BY THE INSUFFICIENTLY TRAINED PERSONNEL

The work related to the maintenance and shipment for repair, can be started:

- after reading these operating instructions,
- after an additional training regarding safe use of the mold,
- Check the screw connections for any looseness
- observing the occupational health and safety regulations applicable in the plant.
- remember that these operating instructions must always be available.



NEVER USE THE MOLD

- under the influence of alcohol,
- under the influence of narcotics or other drugs,
- under the influence of medicines which affect the psychomotor capability.

7.1. Cleaning after disassembly



HAZARD CAUSED BY FALLING HEAVY ELEMENTS

- Do not stand or walk under suspended loads.
- The transport of the mold is permissible only by the qualified personnel with licences to operate lifts.
- Both the die and the compression head may only be lifted on elements provided for this purpose.
- Use only the allowed auxiliary measures with sufficient load-bearing capacity.
- During the transport of the mold, always wear protective footwear.
- Use the personal protection equipment recommended for a given activity in accordance with the in-house regulations.
- Observe the plant occupational health and safety manuals.



PREPARATION OF THE COMPRESSION HEAD FOR CLEANING

- Transport the compression head to the planned cleaning place by means of the appropriate lifting device, observing the occupational health and safety regulations.
- Put the compression head away carefully on the pallet or on wooden beams, so as to prevent the delicate edges of compression head plates (feet) from being damaged.
- Lift the compression head one-sidedly by means of a chain or belts (at an angle).
- Hold the compression head in a tilt position on the pallet or wooden beams, owing to which it is also possible to clean the compression head from the bottom (feet).

PREPARATION OF THE DIE FOR CLEANING

- Using an appropriate lifting device, transport the die to the planned cleaning place, observing the occupational health and safety regulations.
- Lift the die one-sidedly by means of a chain or belts making sure that it does not get damaged.
- Hold the die in a slanting position on the pallet or wooden beams, owing to which it is also possible to clean the die from the bottom.



HAZARD CAUSED BY EJECTED ELEMENTS AND WATER JET

- Always wear safety glasses and protective gloves.
- On top of this, observe the safety regulations for the used cleaning device. Concrete fragments may be ejected from the mold under the influence of the force of the pressure cleaning device



CLEANING OF THE MOLD WITH A WATER JET

- You must not use cleaning and anti-adhesive agents which contain acid.
- You must not immerse the mold in an acid bath. Otherwise, corrosive damage may occur in the mold.



HAZARDS CAUSED BY SHARP EDGES

- Always wear protective gloves.
- The protective gloves allow for the avoidance of injuries by sharp edges during the cleaning of the mold.

THE DEPOSITED RESIDUES MUST BE REMOVED BY MEANS OF A WIRE BRUSH.

- In order to clean (scrape) the mold cavities, do not use tools with sharp edges, such as a chisel, a screwdriver and etc.
- Do not use a hammer, a pneumatic hammer, etc., which may cause the notches and cracks in the mold.
- The mold components must be cleaned by means of a pressure wash.
- Stubborn deposits must be removed with a wire brush.

7.2. Maintenance and storage.



HAZARDS CAUSED BY THE MATERIAL AND SUBSTANCE

- Always wear safety glasses and protective gloves.
- Observe the guidelines given in the material safety data sheet attached to the used preservative.
- Do not breathe in the vapours coming from preservatives.
- The shuttering oils may cause eye and skin irritation.
- After cleaning, sprinkle the working surfaces of the die and the compression head with the shuttering oil.
- During a longer downtime of the machine, sprinkle the mold with the shuttering oil also when the mold is folded.
- Store the mold always on the whole pallet with provided spacers.
- Store the mold in a dry room.
- The activities listed above allow for the failure-free operation of the mold.

7.3. Control and repairs.

Service and repair work may be conducted only by the professional personnel trained in the scope of the performed repairs.

- After each use, check the mold in terms of possible damage.
- Check the welds in terms of scratches and cracks.
- Mark the possible damaged sites and notify the rescue services.
- Make sure that the damaged mold is not used until it is repaired.

7.4. Shipment for repair.



HAZARD CAUSED BY FALLING HEAVY ELEMENTS

- Do not stand or walk under suspended loads.
- The transport of the mold is permissible only by the qualified personnel with licences to operate lifts



HAZARD CAUSED BY FALLING HEAVY ELEMENTS

- Both the die and the compression head may only be lifted on elements provided for this purpose.
- Use only the allowed auxiliary measures with sufficient load-bearing capacity.



HAZARD CAUSED BY FALLING HEAVY ELEMENTS

- During the transport of the mold, always wear protective footwear.
- Use the personal protection equipment recommended for a given activity in accordance with the plant regulations.
- Observe the plant occupational health and safety manuals.

In the case of transport of the mold for repair at the manufacturer's site, protect the mold appropriately for the transport by truck.

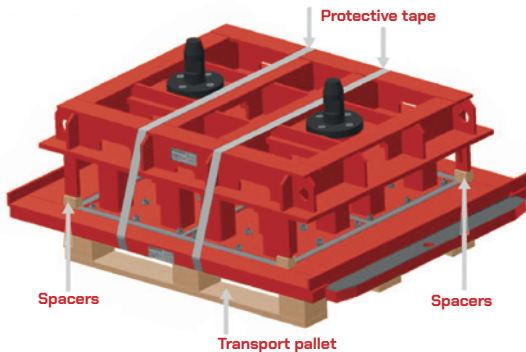
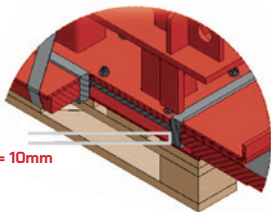
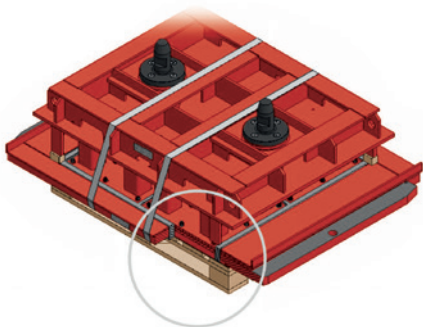

Fig. 15 - Mold properly secured for transport.

- The mold for transport must be cleaned in a manner described in section 7.1.
- The mold must be maintained in a manner described in section 7.2.
- Place the mold on the entire transport pallet whose size is appropriate.
- Insert the spacers between the compression head limiter and the die.
- The size of the spacer should be such that after the mold is assembled, the compression head plates (feet) are about 10 mm above the bottom of the die.



Minimum distance = 10mm

Fig. 16 - Minimum recommended spacing of the foot from the bottom of the die (top of the pallet).

- The mold on the pallet must be secured with the protective tape.

Remember to use protective corners on the edges, which prevent the abrasion of the tape.



8. DISASSEMBLY AND WASTE DISPOSAL



SAFE DISPOSAL OF THE MOLD

- The mold must be disposed of in accordance with the applicable recycling regulations.
- The mold may be returned to the mold manufacturer.
- Before sending the mold for disposal, the prior notification of the shipment is required.
- The compression head of the mold may be used again for the new die. With the proper operation, the compression head is used 2-3 times. In order to use the compression head for another mold, place it on a pallet with a suitable size and protect it with tapes which prevent the compression head from movement.

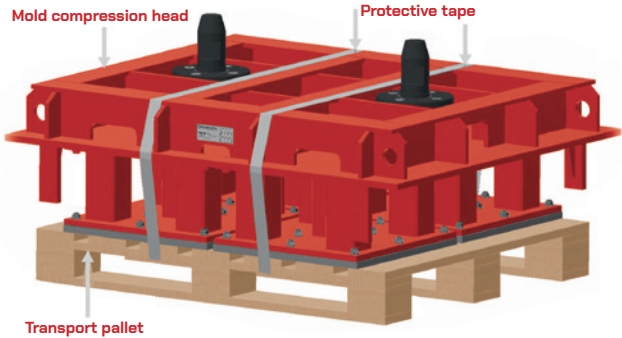

Fig. 17 - Compression head properly secured for transport.

- If a new mold is ordered, using the old construction of the compression head, it is necessary to provide the serial number from the nameplate and the name of the mold in which it was used.

9. CONTACT DETAILS

Our consultants remain at your disposal; they will present you with the details of our offer, help you in the selection of a solution adapted to your requirements and assist you in all the formal processes related to cooperation with our company. You are kindly invited to contact us and we hope that you will be satisfied with our products.

ADDRESS

ul. Żółkiewskiego 131 / 133
26-610 Radom
POLSKA
N 51° 24.926' / E 21° 11.935'

DOMESTIC SALES



phone: +48 48 369 08 86
mob.: +48 608 422 600
mob.: +48 532 859 001
e-mail: sprzedaz@techmatik.com

MAINTENANCE / SPARE PARTS

phone: +48 48 369 08 40
mob.: +48 608 611 611
e-mail: serwis@techmatik.com

MOLD RECONDITION

phone: +48 48 369 08 31
mob.: +48 608 422 500
mob.: +48 668 122 022
e-mail: renewal@techmatik.com

SECRETARIAT

ph.: +48 48 369 08 00
e-mail: techmatik@techmatik.com

INTERNATIONAL SALES



phone: +48 48 369 08 86
mob.: +48 532 859 002
mob.: +48 539 695 455
e-mail: sales@techmatik.com



phone: +48 48 369 08 86
mob.: +49 172 630 939
mob.: +48 604 220 465
e-mail: verkauf@techmatik.com



phone: +48 48 369 08 86
mob.: +48 608 422 100
mob.: +48 512 028 028
e-mail: sales@techmatik.com

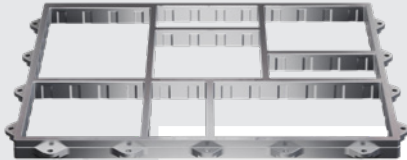
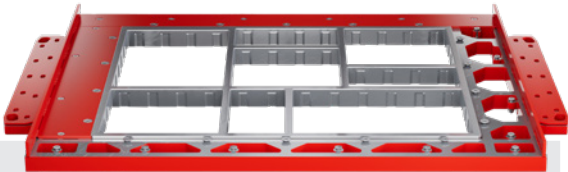
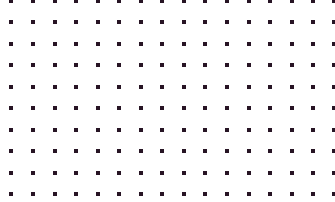



TECHMATIK[®]
A COLUMBIA MACHINE, INC. COMPANY



www.techmatik.com